

ECE 733
Midterm Spring 2011

Name: _____

Student Number: _____

The exam is open book, open notes. No computers are permitted. **75 minutes.**
Write your name and student number on top of this sheet of paper and turn that in. Please write your answer in the space provided after each question. Note there is space to expand on any multiple choice answers.

Question 1 [20 points]

Consider the flip-flop below.

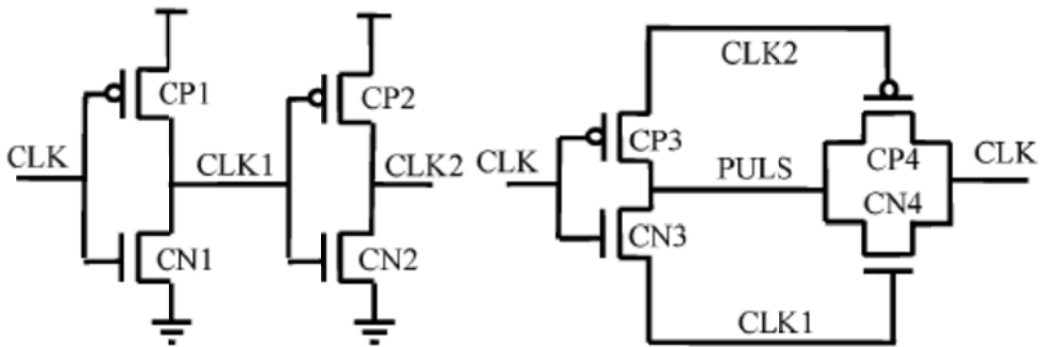

(a)

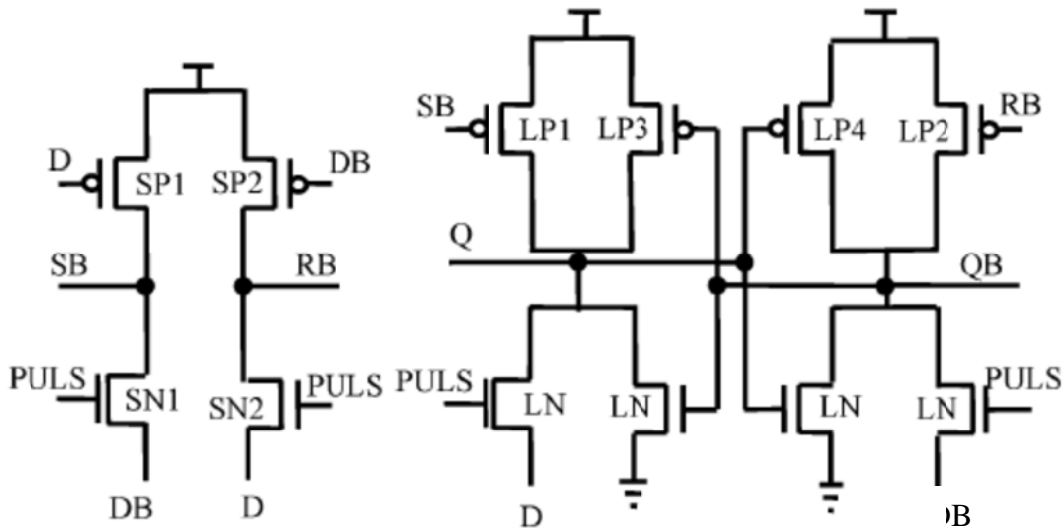

(b)

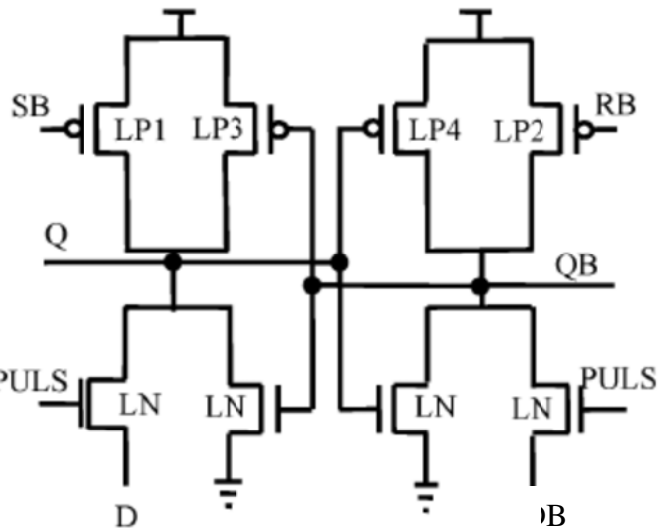

(c)

Please answer the following questions:

- (a) Using the following diagrams explain clearly how the clock pulse generator works. Refer to the labels 1..6. (2,3) and (5,6) are separate by about one inverter delay. [4 points]

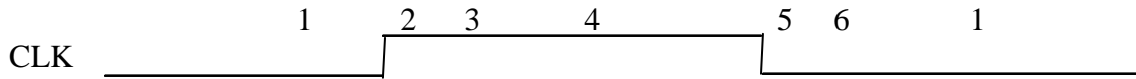

CLK1

CLK2

PULS

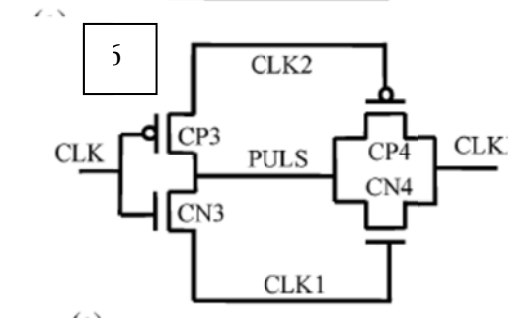
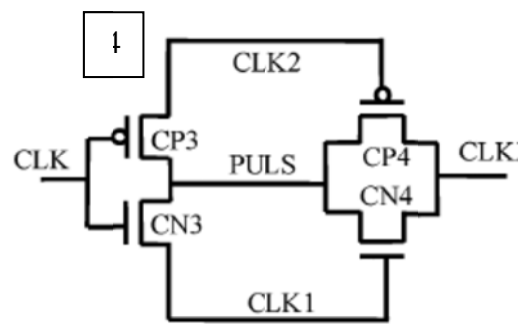
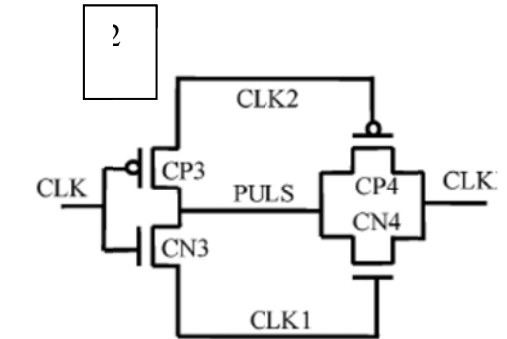
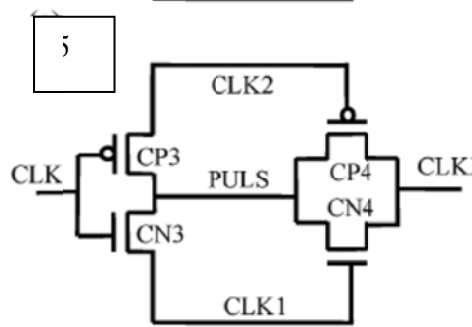
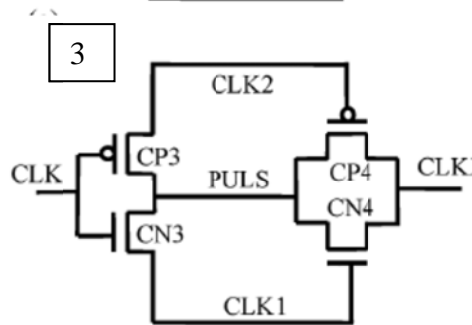
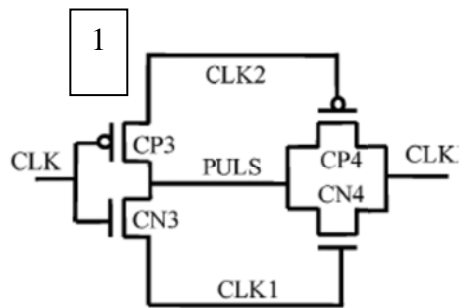

(b) Complete the following waveform for the case. $DB = \text{inverse of } D$. Use X if unknown. Include relative delays. Clearly show floating nodes. [5 points]

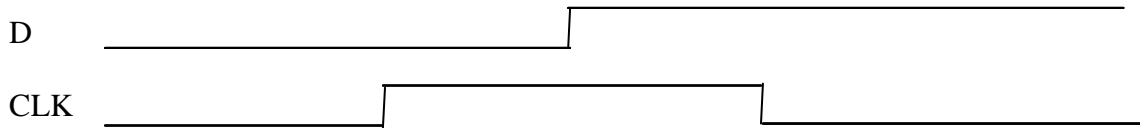

PULS
 SB
 RB
 Q
 QB

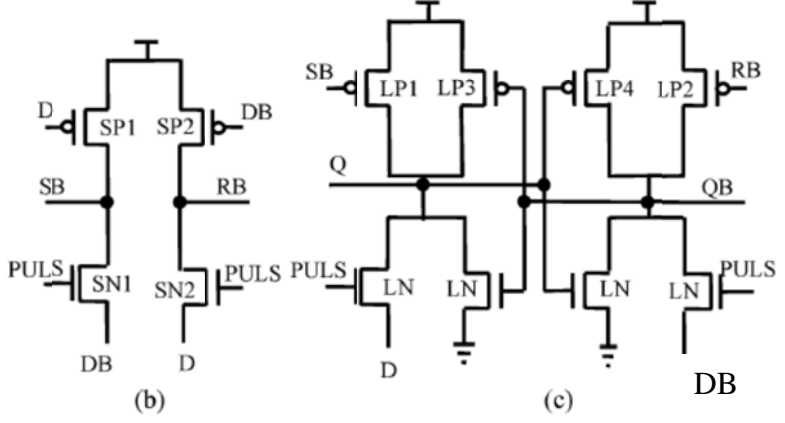
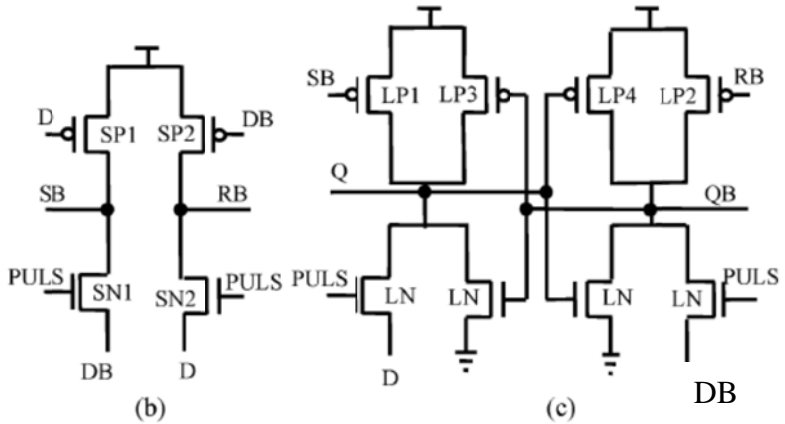

(d) What transistors determines the limits on setup time, and the hold time of the Flip-Flop? Clearly show the range(s) of the “forbidden zone” in the plot below. [5 points]

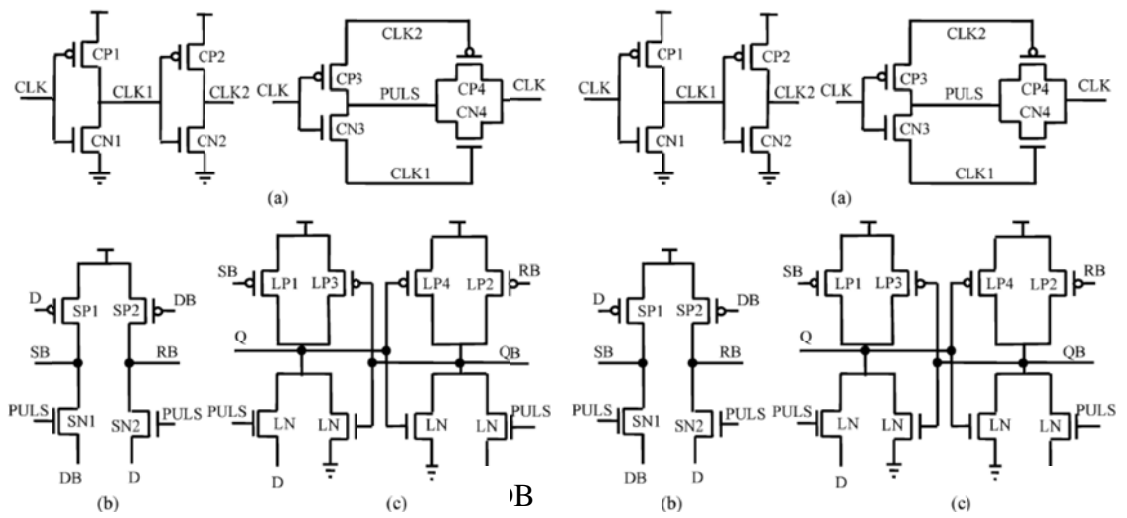

(g) Are there any floating nodes during the operation of this flip-flop? Do they present any danger to correct operation? Refer back to your answer in (b). [3 points]

(i) How is the storage overcome, is the latch broken or over-powered? [1 points]

(j) What is the value of the SB/RB generator? Why not just drive LP1/2 with D/DB? [2 points]